

Model 266 & 267

Submersible Sewage, Effluent or Dewatering Pumps

Features:

- Split phase or 3 phase
- 1/2 hp 115-460 V
- Performance up to 21.5' (6.6 m)
- Flows up to 128 GPM (484 LPM)
- Cast iron cap, motor housing, and pump housing
- Cast iron or engineered plastic base
- Non-clogging vortex impeller
- Corrosion-resistant, powder coated epoxy paint



100% factory tested



Trusted. Tested. Tough.[®]
zoellerpumps.com 800-918-7867
3649 Cane Run Road, Louisville, KY 40211 USA

FM3121

PRODUCT SPECIFICATIONS

MOTOR	Horse Power	1/2
	Voltage	115 - 460
	Phase	1 or 3 Ph
	Hertz	60 Hz
	RPM	1725
	Type	Split phase or 3 Ph
	Insulation	Class B
	Amps	1.5 - 10.4
PUMP	Operation	Automatic or nonautomatic
	Auto On/Off Points	12" (30 cm) / 4" (10 cm)
	Discharge Size	2" female or 3" NPT male
	Solids Handling	2" (50 mm) spherical solids
	Cord Length	10' (3 m) automatic or 15' (5 m) nonautomatic
	Cord Type	UL listed neoprene cord and plug
	Max. Head	21.5' (6.6 m)
	Max. Flow Rate	128 GPM (484 LPM)
	Max. Operating Temp.	130 °F (54 °C)
	Cooling	Oil filled
	Motor Protection	Auto reset thermal overload (1 Ph)
	MATERIALS	Cap
Motor Housing		Cast iron
Pump Housing		Cast iron
Base		Cast iron or engineered plastic
Upper Bearing		Sleeve bearing
Lower Bearing		Sleeve bearing
Mechanical Seals		Carbon and ceramic
Impeller Type		Non-clogging vortex
Impeller		Engineered plastic w/ metal insert
Hardware		Stainless steel
Motor Shaft		AISI 1215 cold rolled steel
Gasket		Neoprene
Min. Basin Size		Simplex: 18" x 30" (45.7 x 76.2 cm) Duplex: 30" x 36" (76.2 x 91.4 cm)

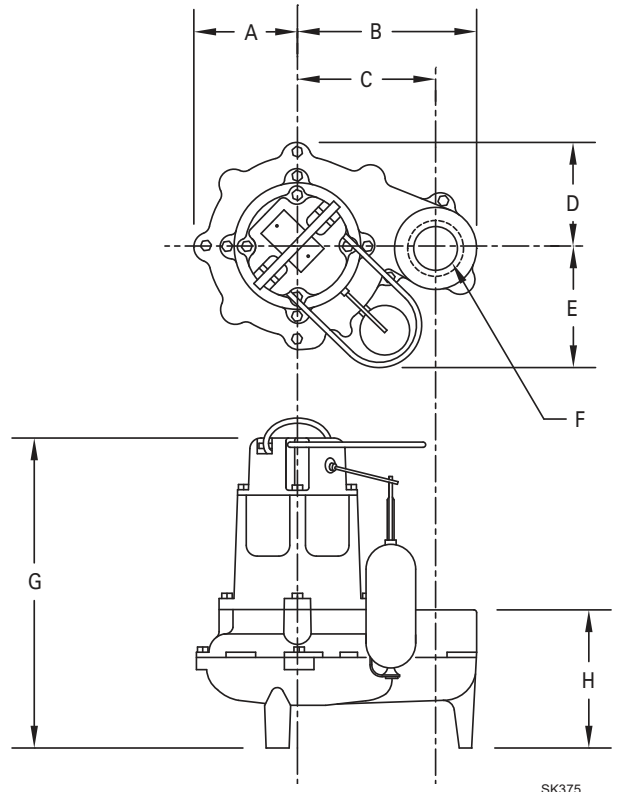

SK375

NOTE: The sizing of effluent systems normally requires variable level float(s) controls and properly sized basins to achieve required pumping cycles or dosing timers with nonautomatic pumps. See model comparison chart for specific details.

* May be used in those states where codes do not restrict solids size in effluent systems.

MODEL		266/267	
Feet	Meters	Gal.	Liters
5	1.5	115	435
10	3.0	85	322
15	4.6	45	170
Shut-off Head:		20.5 ft.(6.2 m)	

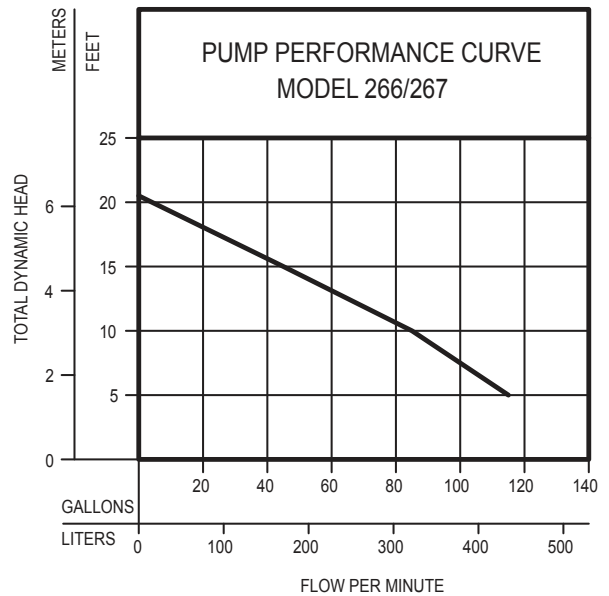

009971



© Copyright 2017 Zoeller® Co. All rights reserved.

502-778-2731 | 800-928-7867 | 3649 Cane Run Road | Louisville, KY 40211-1961 | zoellerpumps.com