

SECTION A-A

NOTES

1. Airline piping to FAST® may not exceed 100 FT [30m] total length and have a maximum of 5 elbows in the piping system. For distances greater than 100FT [30m] consult factory. Blower must be located above flood levels on a concrete base 26" X 20" X 2" [65 X 50 X 5cm] min.
2. Vent to desired location and cover opening with a vent grate with at least 7 sq in. [45 sq. cm] open surface area. Secure with stainless steel screws. Vent piping must not allow condensate build up or create back pressure. Vent must be above finished grade or higher.
3. All appurtenances to FAST® (e.g. tanks, access ports, electrical, etc.) must conform to all applicable country, state, province, and local plumbing and electrical codes. Pump out access shall be adequate to thoroughly clean out the tank.
4. All inspection, viewing and pump out ports must be secured to prevent accidental or unauthorized access.
5. Tank, piping, conduit, etc. are provided by others. Blower & optional blower control system by Bio-Microbics, Inc. See Installation Manual.
6. All inspection, viewing and pump out ports must be secured to prevent accidental or unauthorized access.
7. Fast® module must be secured by bolting through straps, then lid is bolted to the tank.
8. If less than the specified minimum is considered necessary, consult factory for guidance.
9. All piping and ancillary equipment installed after FAST must not impede or restrict free flow of effluent.
10. Specialized treatment levels may require specific features to be incorporated into the design. Consult factory for guidance.
11. Effluent hole will accept a 3" SCH 40 PVC pipe which can be then inserted into the existing 4" Discharge pipe in the septic tank. The RetroFAST® provides vigorous aeration in a septic tank which reverses the clogging process in a drain field.
12. Nitrogen reduction beyond standard levels may require specific features to be incorporated into the tank design. Consult factory for guidance.
13. See *RetroFAST 0.375* drawing for additional details and specifications.

DO NOT SCALE UNLESS NOTED DIMENSIONS ARE IN INCHES [CENTIMETERS] TOLERANCES ± 0.02 IN/IN [± 0.05 CM/CM]			
Infiltrator 1530 MCF Installation			
WEIGHT	lb	SIZE	DRAWING NUMBER
NAME	DATE	A	0.375 RetroFAST Layout
DRAWN	CTC 3/7/2012		
CHECKED	PF 4/23/2015		REVISED 4/23/2015
			REV. INI-01-D

THE INFORMATION CONTAINED IN THIS DRAWING IS THE SOLE PROPERTY OF BIO-MICROBICS INC. ANY REPRODUCTION IN PART OR AS A WHOLE WITHOUT THE WRITTEN PERMISSION OF BIO-MICROBICS INC. IS PROHIBITED. DESIGN AND INVENTION RIGHTS ARE RESERVED. IN THE INTEREST OF TECHNOLOGICAL ADVANCEMENT, ALL PRODUCTS ARE SUBJECT TO DESIGN AND OR MATERIAL CHANGE WITHOUT NOTICE.

BIO-MICROBICS © 2015

SHEET 1 OF 4

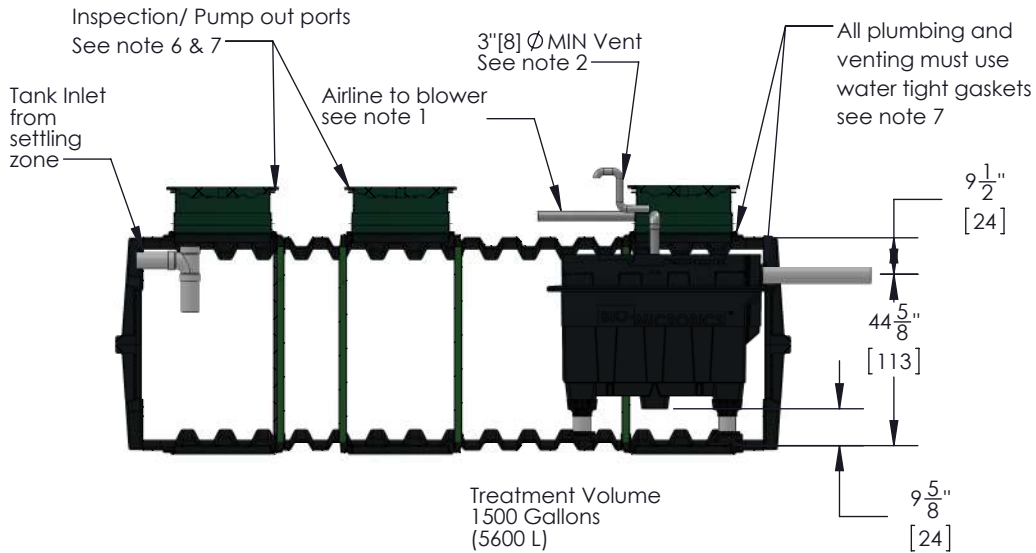
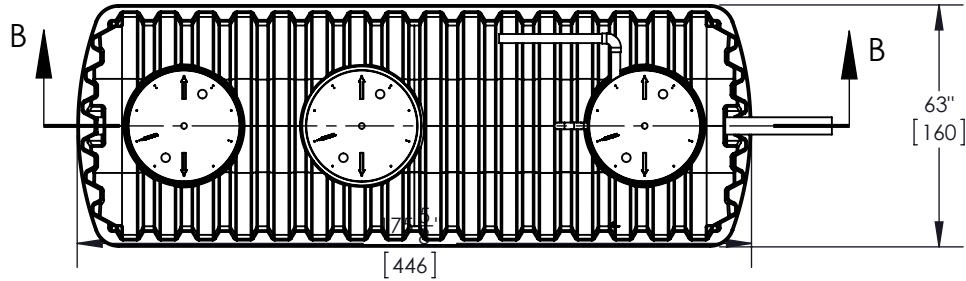

SECTION B-B

NOTES

1. Airline piping to FAST® may not exceed 100 FT [30m] total length and have a maximum of 5 elbows in the piping system. For distances greater than 100FT [30m] consult factory. Blower must be located above flood levels on a concrete base 26" X 20" X 2" [65 X 50 X 5cm] min.
2. Run Vent to desired location and cover opening with a vent grate with at least 7.1 sq in. [45.8 sq. cm] open surface area. Secure with stainless steel screws. Vent piping must not allow condensate build up or create back pressure. Vent must be above finished grade or higher (See MicroFAST®0.50 FAST Unit Sheet 4 of 4 for additional details).
3. All appurtenances to FAST® (e.g. tank pump outs, etc.) must conform to all applicable country, state, province, and local plumbing and electrical codes. Pump out access shall be adequate to thoroughly clean out both zones.
4. If less than the specified minimums are considered necessary, consult factory for approval.
5. The primary compartment is a separate chamber or tank, additional recycling may be required.
6. All inspection, viewing and pump out ports must be secured to prevent accidental or unauthorized access.
7. Tank, piping, conduit, ect. are provided by others. Blower control system by Bio-Microbics, Inc. See Installation Manual
8. All piping and ancillary equipment installed after FAST must not impede or restrict free flow of effluent.
9. The air supply line into the FAST® unit must be secured to prevent vibration induced damage.
10. Height is reduced reference "Short-FAST-Module-Procedure.pdf"
11. Refer to Bio-Microbics "Installation Guidelines for FAST® into IM-1530" for additional details.
12. Nitrogen reduction beyond standard levels may require specific features to be incorporated into the tank design. Consult factory for guidance.
13. See MicroFAST® 0.50 FAST Unit for additional details & specifications.

DO NOT SCALE UNLESS NOTED DIMENSIONS ARE IN INCHES [CENTIMETERS] TOLERANCES ± 0.02 IN/IN [± 0.05 CM/CM]		 BETTER WATER. BETTER WORLD.® Infiltrator 1530 MCF Installation	
WEIGHT	lb	SIZE	DRAWING NUMBER
		A	0.5 MicroFAST Layout
DRAWN	CTC	DATE	3/7/2012
CHECKED	PF	DATE	4/23/2015
		REVISED	4/23/2015
		REV.	INI-01-D

THE INFORMATION CONTAINED IN THIS DRAWING IS THE SOLE PROPERTY OF BIO-MICROBICS INC. ANY REPRODUCTION IN PART OR AS A WHOLE WITHOUT THE WRITTEN PERMISSION OF BIO-MICROBICS INC. IS PROHIBITED. DESIGN AND INVENTION RIGHTS ARE RESERVED. IN THE INTEREST OF TECHNOLOGICAL ADVANCEMENT, ALL PRODUCTS ARE SUBJECT TO DESIGN AND OR MATERIAL CHANGE WITHOUT NOTICE.

BIO-MICROBICS © 2015

SHEET
2 OF 4

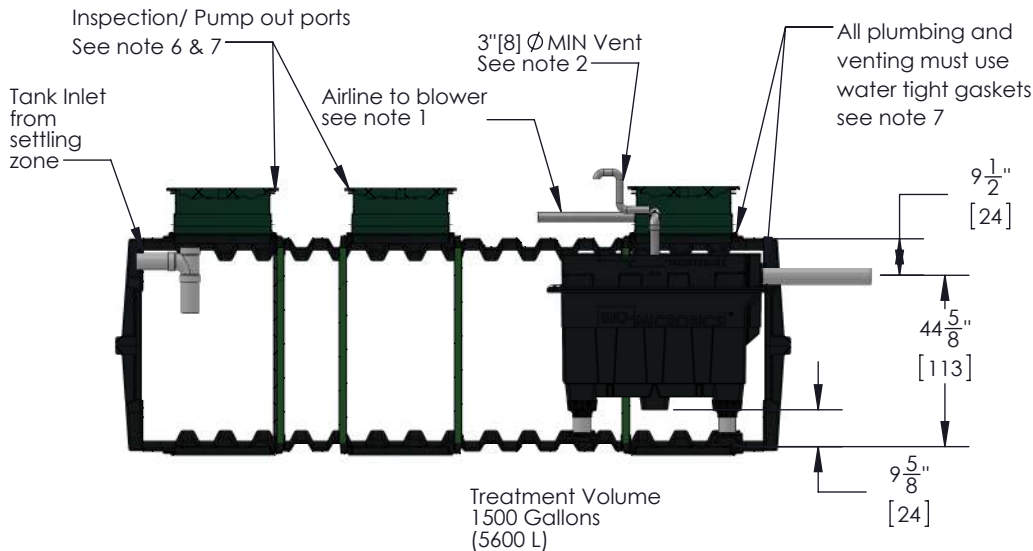
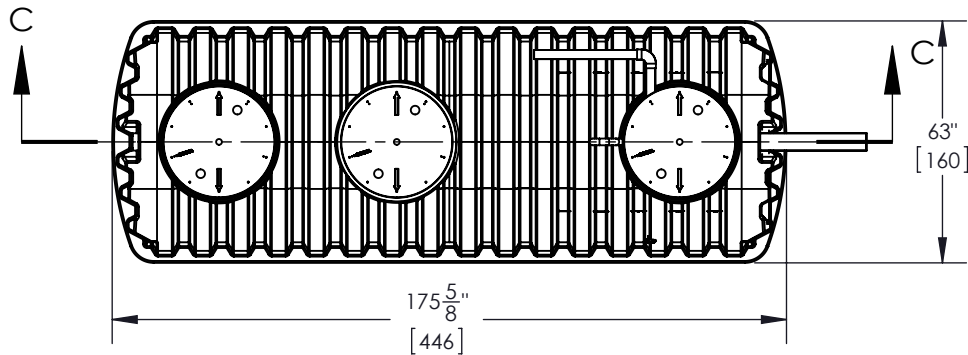

SECTION C-C

NOTES

1. Airline piping to FAST® may not exceed 100 FT [30m] total length and have a maximum of 5 elbows in the piping system. For distances greater than 100FT [30m] consult factory. Blower must be located above flood levels on a concrete base 26" X 20" X 2" [65 X 50 X 5cm] min.
2. Run Vent to desired location and cover opening with a vent grate with at least 7.1 sq in. [45.8 sq. cm] open surface area. Secure with stainless steel screws. Vent piping must not allow condensate build up or create back pressure. Vent must be above finished grade or higher (See MicroFAST® 0.625 FAST Unit Sheet 4 of 4 for additional details).
3. All appurtenances to FAST® (e.g. tank pump outs, etc.) must conform to all applicable country, state, province, and local plumbing and electrical codes. Pump out access shall be adequate to thoroughly clean out both zones.
4. If less than the specified minimums are considered necessary, consult factory for approval.
5. The primary compartment is a separate chamber or tank, additional recycling may be required.
6. All inspection, viewing and pump out ports must be secured to prevent accidental or unauthorized access.
7. Tank, piping, conduit, ect. are provided by others. Blower control system by Bio-Microbics, Inc. See Installation Manual
8. All piping and ancillary equipment installed after FAST must not impede or restrict free flow of effluent.
9. The air supply line into the FAST® unit must be secured to prevent vibration induced damage.
10. Height is reduced reference "Short-FAST-Module-Procedure.pdf"
11. Refer to Bio-Microbics "Installation Guidelines for FAST® into IM-1530" for additional details.
12. Nitrogen reduction beyond standard levels may require specific features to be incorporated into the tank design. Consult factory for guidance.
13. See *MicroFAST 0.625 FAST Unit* for additional details & specifications.

DO NOT SCALE UNLESS NOTED DIMENSIONS ARE IN INCHES [CENTIMETERS] TOLERANCES ± 0.02 IN/IN [± 0.05 CM/CM]		 BETTER WATER. BETTER WORLD.® Infiltrator 1530 MCF Installation	
WEIGHT	lb	SIZE	DRAWING NUMBER
		A	0.625 MicroFAST Layout
DRAWN	CTC	DATE	3/7/2012
CHECKED	PF	DATE	4/23/2015
		REVISED	4/23/2015
		REV.	INI-01-D

THE INFORMATION CONTAINED IN THIS DRAWING IS THE SOLE PROPERTY OF BIO-MICROBICS INC. ANY REPRODUCTION IN PART OR AS A WHOLE WITHOUT THE WRITTEN PERMISSION OF BIO-MICROBICS INC. IS PROHIBITED. DESIGN AND INVENTION RIGHTS ARE RESERVED. IN THE INTEREST OF TECHNOLOGICAL ADVANCEMENT, ALL PRODUCTS ARE SUBJECT TO DESIGN AND OR MATERIAL CHANGE WITHOUT NOTICE.

BIO-MICROBICS © 2015

SHEET
3 OF 4

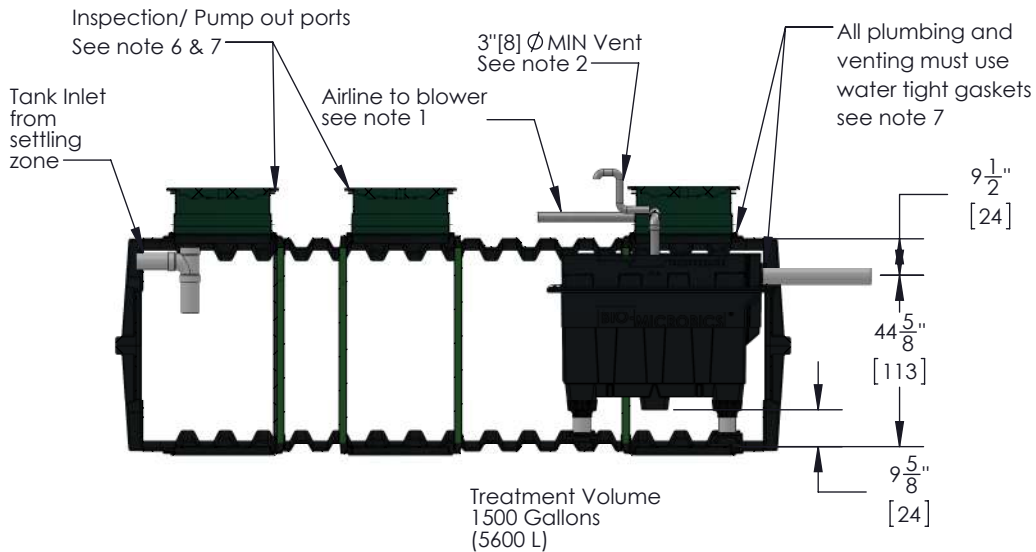
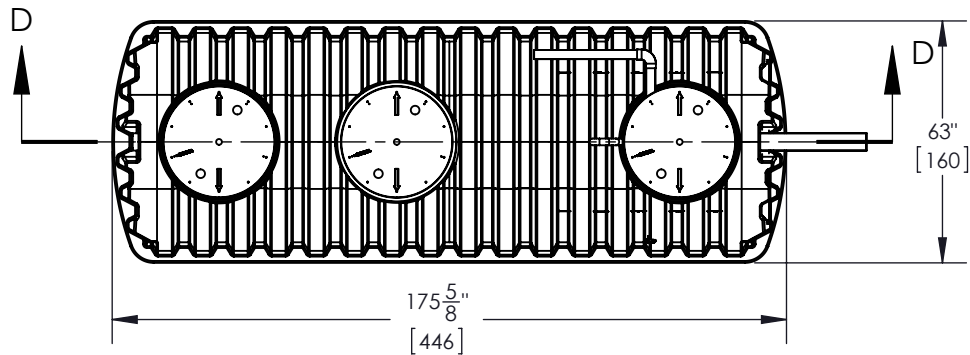

SECTION D-D

NOTES

1. Airline piping to FAST® may not exceed 100 FT [30m] total length and have a maximum of 5 elbows in the piping system. For distances greater than 100FT [30m] consult factory. Blower must be located above flood levels on a concrete base 26" X 20" X 2" [65 X 50 X 5cm] min.
2. Run Vent to desired location and cover opening with a vent grate with at least 7.1 sq in. [45.8 sq. cm] open surface area. Secure with stainless steel screws. Vent piping must not allow condensate build up or create back pressure. Vent must be above finished grade or higher (See MicroFAST®0.75 FAST Unit Sheet 4 of 4 for additional details).
3. All appurtenances to FAST® (e.g. tank pump outs, etc.) must conform to all applicable country, state, province, and local plumbing and electrical codes. Pump out access shall be adequate to thoroughly clean out both zones.
4. If less than the specified minimums are considered necessary, consult factory for approval.
5. The primary compartment is a separate chamber or tank, additional recycling may be required.
6. All inspection, viewing and pump out ports must be secured to prevent accidental or unauthorized access.
7. Tank, piping, conduit, ect. are provided by others. Blower control system by Bio-Microbics, Inc. See Installation Manual
8. All piping and ancillary equipment installed after FAST must not impede or restrict free flow of effluent.
9. The air supply line into the FAST® unit must be secured to prevent vibration induced damage.
10. Height is reduced reference "Short-FAST-Module-Procedure.pdf"
11. Refer to Bio-Microbics "Installation Guidelines for FAST® into IM-1530" for additional details.
12. Nitrogen reduction beyond standard levels may require specific features to be incorporated into the tank design. Consult factory for guidance.
13. See *MicroFAST 0.75 FAST Unit* for additional details & specifications.

DO NOT SCALE				Infiltrator 1530 MCF Installation	
UNLESS NOTED DIMENSIONS ARE IN INCHES [CENTIMETERS] TOLERANCES ± 0.02 IN/IN [± 0.05 CM/CM]					
WEIGHT	lb	SIZE	DRAWING NUMBER		SHEET 4 OF 4
		A	0.75 MicroFAST Layout		
DRAWN	CTC	DATE	3/7/2012		
CHECKED	PF	DATE	4/23/2015		
			REVISED	4/23/2015	REV. INI-01-D

THE INFORMATION CONTAINED IN THIS DRAWING IS THE SOLE PROPERTY OF BIO-MICROBICS INC. ANY REPRODUCTION IN PART OR AS A WHOLE WITHOUT THE WRITTEN PERMISSION OF BIO-MICROBICS INC. IS PROHIBITED. DESIGN AND INVENTION RIGHTS ARE RESERVED. IN THE INTEREST OF TECHNOLOGICAL ADVANCEMENT, ALL PRODUCTS ARE SUBJECT TO DESIGN AND OR MATERIAL CHANGE WITHOUT NOTICE.

BIO-MICROBICS © 2015